

Nkemakolam Chinedu Izuwa, Stanley Toochukwu Ekwueme, Ndubuisi Uchechukwu Okereke, Onyebuchi Ivan Nwanwe, Nnaemeka Princewill Ohia

Federal University of Technology, Department of Petroleum Engineering, Owerri (FUTO), Nigeria

Scientific paper

ISSN 0351-9465, E-ISSN 2466-2585

<https://doi.org/10.62638/ZasMat1009>



Zastita Materijala 65 (1)

73 - 85 (2024)

Comparative analysis of geothermal binary ORC systems: performance and environmental considerations for CO₂ and water as geofluids

ABSTRACT

This study considers the process simulation of geothermal binary Organic Rankine Cycle (ORC) systems which utilizes CO₂ and water as geofluids for electricity generation. The simulation was performed using Hysys v11 software by using Peng Robinson's fluid property package. Two dry working fluids including isopentane and n-pentane, were used. The effects of geofluid temperature and working fluid mass flowrate on power generation, as well as the maximum pressure of working fluids were evaluated. The result showed that power generation increases with higher geofluid temperature due to enhanced heat transfer. Isopentane outperformed n-pentane, attributed to its superior thermodynamic properties. CO₂ showed better performance as geofluid than water highlighting its superiority, observed in the increased power generation. The unique characteristics of CO₂ enable efficient heat transfer at lower temperatures, making it an environmentally friendly and effective choice. Contrarily, the use of water as a geofluid poses some implications for local ecosystems and water resources. From an environmental perspective, CO₂ shows greater potential for reduced environmental impact, which aligns with the transition to cleaner energy sources. However, the economic considerations suggest a trade-off, as CO₂ projects may entail higher upfront costs compared to water-based systems. Regulatory factors and economic feasibility, therefore, play a crucial role in the choice of geofluid for geothermal power generation.

Keywords: Geofluid, working fluid, ORC, renewable energy

1. INTRODUCTION

In recent times, there has been increasing pressure to raise the proportion of renewable energy sources in electricity generation. This push has opened up opportunities for the development of geothermal energy in regions that were previously deemed unviable for this purpose [1].

Global concerns such as climate change, ozone layer depletion, rising electrical energy demand, and diminishing fossil fuel reserves have driven advancements in renewable energy technology. While wind and solar farms are gaining popularity, they are subject to weather-dependent operation [2]. Consequently, they require collaboration with traditional power plants and the advancement

of energy storage solutions, including the exploration of underground caverns and fuel cell technology [3,4]. On the other hand, biomass combustion, hydroelectric, and geothermal power plants offer relatively stable or cyclical renewable energy [5]. However, biomass power plants, despite their potential for compact construction, necessitate substantial quantities of low-energy feedstocks, often requiring significant land areas, unless utilizing waste materials. Hydroelectric power plants, in turn, can cause notable environmental contamination of local water sources [6]. Geothermal power plants stand out for their minimal surface impact on the environment. They extract heat energy by drilling deep into the earth [7].

Geothermal energy serves various purposes, including electricity and heat generation, combined heat and power applications, and space heating and cooling. It is broadly categorized into three temperature ranges: high temperature (above 150°C), intermediate temperature (between 90°C and 150°C), and low temperature (below 90°C)

*Corresponding author: Izuwa, N.C.

E-mail: Stanleyekwueme@yahoo.com

Paper received: 21. 09. 2023.

Paper accepted: 07. 10. 2023.

Paper is available on the website: www.idk.org.rs/journal

resources [8]. These applications can be classified into power generation and direct use [9].

Geothermal power plants fall into three types: flash, dry-steam, and binary, each suitable for different temperature ranges. Flash and dry-steam technologies are employed with higher temperature sources (above 180°C), while binary plants utilize lower temperature sources (from lower than 180°C) [9]. Globally, flash, dry-steam, and binary technologies comprise 58%, 26%, and 15% of the market, with emerging technologies constituting 1% of facilities [9].

The flash technology is well-established and used when the geothermal fluid contains both liquid and vapor phases at the wellhead, typically above 180°C [10]. In this method, the geothermal fluid undergoes a direct cycle: it is flashed to separate steam, which then drives a steam turbine before being condensed. The plant design depends on the geothermal fluid's composition, often containing salts and non-condensable gases (NCG) [10]. Treatment of the fluid, including NCG extraction for proper condenser operation, is essential. Depending on chemical composition, NCG may undergo further treatment or be released into the environment. Geothermal fluids can have varying chemical compositions, often including CO₂, H₂S, and sometimes hydrocarbons [9].

Binary cycle technology employs two separate cycles: a geothermal loop and a power cycle (ORC or Kalina cycle). This approach is commonly used for liquid sources or medium-low-temperature resources (typically 100-170°C) [11]. A significant benefit of the binary cycle is the enclosed geothermal fluid loop, which prevents environmental pollution by containing potential pollutants and reinjecting them underground. In ORC binary geothermal power plants, organic working fluids are used [10].

Several research has been conducted on the performance of different working fluids in Organic Rankine Cycle (ORC) systems, Pasetti et al. [12] investigated decomposition temperatures for n-butane, toluene, and n-pentane, with toluene remarkably stable at around 400°C, n-pentane stable below 315°C, and n-butane stable near 290°C. Notably, n-butane (R600), n-pentane, cyclopentane, hexamethyldisiloxane (MM), and toluene demonstrate higher thermal stability, making them suitable for geothermal solar hybrid applications. However, the existing literature lacks extensive analysis of these working fluids in such hybrid systems.

Ashouri et al. [13] investigated a small-scale ORC coupled with a parabolic trough solar collector in Tehran, favouring benzene for net electric efficiency. However, they didn't consider the impact

of the Solar Heat Transfer Fluid on working fluid performance.

Salman et al. [14] conducted research comparing n-butane (R600), R236ea, R245fa, and n-hexane as working fluid using solar heat fluid in Aspen Plus software. They showed that n-butane possesses superior thermal efficiency at 13.55% within the 70°C–90°C range. However, their study did not consider the analysis of the impact of solar heat fluid on organic working fluid performance, as well as pump power requirements and network output. Additionally, they analyzed R245fa with a high Global Warming Potential (GWP) of 1030.

Najjar and Qatramez [15] studied various working fluids for ORC power generation using a geothermal temperature source of 200°C–260°C. Their study identified R11 with the highest net power output (24.89 MW) and efficiency (18.76%), however, its high GWP (4750) makes it unsuitable for ORC applications.

Wang et al. [16] compared small ORC systems powered by solar, using R245fa, R134a, and isobutane as working fluids. Their results showed that a thermal-driven pump solar system outperforms the conventional system for residential use. In another study, Wang et al. [17] performed a thermodynamic economic analysis of a solar-powered ORC, they showed that isobutane as the optimal working fluid for small-scale systems.

Song et al. [18] studied geothermal ORC systems and found that low critical temperature working fluids perform better when superheated, but higher critical temperature fluids degrade when superheated. In a subsequent study, Song et al. [19] performed a thermodynamic and financial analysis of carbon dioxide-ORC systems for hybrid geothermal and solar electricity generation, they concluded that the hybrid systems are superior.

2. GEOTHERMAL ENERGY

Geothermal energy refers to the energy harnessed from the internal heat of the earth. It represents a sustainable and renewable alternative to fossil fuels, which makes it attractive. Geothermal energy source is particularly well-suited for providing consistent base-load power due to its minimal variability [20]. Geothermal energy has various applications which includes both electricity and heat generation, being utilised for combined heat and power needs, as well as space heating and cooling requirements [21].

The advantages of geothermal energy are substantial. Geothermal power plants can reliably be operated for over 7000 hours annually, contributing to the stability of power grids [21]. With proper reservoir management, these power plants

can have an extended operational lifespan. However, it is worthwhile to note that reservoir water balance management is critical for ensuring sustainable and effective geothermal power plant operation [2].

Numerous studies centred around the modelling of geothermal power plants, principally focuses on two key aspects: power generation and reinjection facilities [2]. The former relates to the production wells and the closed power cycle, while the latter involves compressor trains and reinjection wells. Among various technologies, the Organic Rankine Cycle (ORC) technology emerges as highly compatible with "closed cycle reservoirs". ORCs show great promise for the conversion of low-temperature geothermal heat into power [2].

2.1. Organic Rankine Cycle (ORC) Systems

The successful exploitation of geothermal resources lies in the efficiency of the technologies adapted to its operation. Power production technologies of the geothermal plants are classified as flash, dry-steam and binary types. Flash and dry-steam types use geothermal sources with higher temperatures (i.e., minimum 220 °C). On the other hand, binary plants utilize sources that have lower temperatures (i.e., from 100 °C to 220 °C) [9].

A critical example of binary cycle turbine for geothermal turbine system is organic Rankine cycle (ORC). ORC have demonstrated capacity to convert low-temperature geothermal fluids to electricity. However, the efficiency of the system is reported to be around 13%. In ORC system, organic working fluids are used, these fluids are basically refrigerants or hydrocarbons [22].

It has been reported that the performance of ORC is largely dependent on the working fluid used. Therefore, choice of organic working fluid is critical and imperative and should be carefully done. The choice of working fluids for Organic Rankine Cycle (ORC) systems is influenced by a range of factors including health, safety, economics, environmental considerations, and thermodynamic properties [23]. The environmental and safety aspects of potential working fluids encompass flammability, toxicity, Global Warming Potential (GWP), and Ozone Depletion Potential (ODP). Organic working fluids, for instance, should possess a GWP below 150 and an absence of ODP [22].

In the selection of an ideal ORC working fluid favourable parameters such as low specific volume, liquid specific heat, viscosity, flammability, toxicity, ODP, GWP, and cost should be considered Bahrami, et al., [22] Moreover, process characteristics like high efficiency, latent heat, density, molecular weight, suitable thermal stability limits, compatibility with turbine materials and lubricating oil, non-corrosiveness, non-inflammability,

and moderate heat exchanger pressures are important [24]. Saturated vapor specific volume is indicative of condenser size, tied to initial system costs. Higher saturation pressure (>100 kPa) prevents gas infiltration, which can reduce system efficiency. A working fluid with high latent heat and density is preferred to optimize output power in a combined cycle.

Working fluids can be categorized into three types: isentropic fluids, dry fluids, and wet fluids, based on the slope of the T-s saturation curve during expansion [25]. Wet fluids have a negative slope, isentropic fluids have a vertical slope, and dry fluids have a positive slope. Water is an example of a wet fluid, while dry fluids include many hydrocarbon gases like propane, butane, pentane, and hexane. Isentropic fluids include toluene and R245fa etc [9].

Water has been largely utilised for large-scale fossil fuel-fired Rankine cycle plants, particularly at high temperatures, but its limitations become significant at lower temperatures. Organic fluids, derived from petroleum, exhibit lower evaporation energy compared to water, requiring less heat for vaporization [23]. Their thermodynamic and chemical characteristics eliminate the need for superheating. Unlike water, most organic fluids result in superheated vapor through a turbine during isentropic expansion, avoiding two-phase mixtures and simplifying turbine and cycle design [24]. Dry working fluids are preferable for ORC use due to erosion concerns associated with droplets from wet fluid expansion. Isentropic fluids, due to their higher GWP, are becoming less favoured [23].

The steady-state energy models for the ORC system are given below

$$\sum \dot{m}_{in} = \sum \dot{m}_{out} \quad (1)$$

$$\sum Q + \sum \dot{m}_{in} h_{in} = \sum W + \sum \dot{m}_{out} h_{out} \quad (2)$$

$$W_{net} = W_{turbine} - W_{pump} \quad (3)$$

$$W_{turbine} = \dot{m}_f (h_{in} - h_{out}) \quad (4)$$

where

\dot{m} (kg/s) is the mass flow rate

h is the specific enthalpy of the system's working fluid streams, (kJ/kg)

Q represent the heat energy passing via the component boundaries, (Watts)

W is the work energy passing via the component boundaries, (Watts).

W_{net} is the network, Watts

$W_{turbine}$ is the turbine work, Watts

W_{pump} is the pump work, Watts

\dot{m}_f is the mass flow rate,

h_{in} is the specific enthalpy at the turbine entry

h_{out} is the specific enthalpy at the exit of the turbine

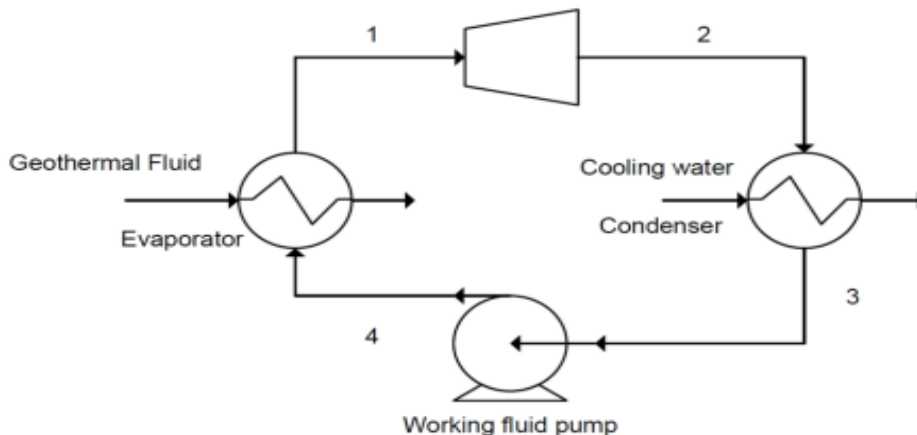

Figure 1. The working principle of the ORC system

Slika 1. Princip rada ORC sistema

Figure 1 describes the working principle of the ORC system.

The binary organic Rankine cycle (ORC) for generation of electricity using geothermal fluids is adequately similar to the conventional binary ORC process. The slight difference is the exclusion of the heat generator where the heat is generated. For the geothermal ORC, the geofluid is a hot fluid from the geothermal wells. The geothermal reservoir acts as the source of heat. As can be observed in figure 1, the geothermal fluid from the well is sent to the evaporator where superheated vapours are generated. usually, fluids with low boiling points are used as working fluids so that they can be easily vapourized. These working fluids gets vapourized upon moderate or low temperature heating by the geothermal fluid [22]. The working fluid is pumped from to the evaporated where it extracts the heat from the geofluid and vapourizes. The vapourized working fluid is sent to the turbine where its heat causes its expansion and is used to rotate the turbine blades generating

electricity. The working fluid after being extracted of its heat leaves the turbine at lower temperature and pressure and goes to the condenser where it is cooled. The cooled working fluid is pumped back to the evaporator to continue the cycle. Meanwhile, the cooled geofluid is injected back into the well [23].

3. METHODS

The methods comprise the process modelling and simulation of binary geothermal system. The heat source is from abandoned oil and gas wells. Geothermal heat is mined using water and supercritical CO₂ as geofluid. The ORC system for electricity generation consists of binary plant modelled with isopentane and n-pentane as working fluids. The geofluids recovered from the well via the wellheads were sent to the ORC system. The process modelling and simulation is summarized using the block diagram given below.

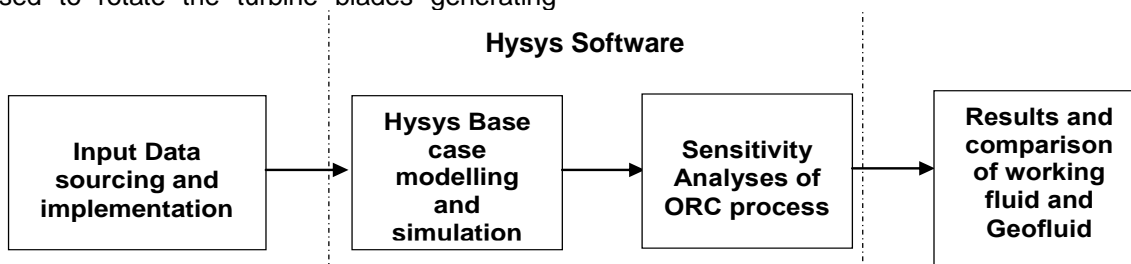

Figure 2. Simulation Process Block Diagram

Slika 2. Blok dijagram procesa simulacije

3.1. Input data

The input data comprises the thermodynamic the fluid parameters comprising the temperature, pressure and mass flowrate of the geofluids and

the working fluids, the process components parameters, and operating conditions of the ORC system.

The input data is given in Table 1.

Table 1. Input data for process simulation

Tabela 1. Ulazni podaci za simulaciju procesa

Parameter	Value
Turbine isentropic efficiency	75%
Turbine polytropic efficiency	74%
Pump Adiabatic efficiency	75%
Ambient temperature	20°C
Water Mass Flowrate (Base)	80 kg/s
Water inlet temp (Base)	100°C
Water Inlet Pressure (Base)	10 bars
CO ₂ Mass Flowrate (Base)	80 kg/s
CO ₂ inlet temp (Base)	100°C
CO ₂ Inlet Pressure (Base)	20 Mpa
Working fluid inlet temperature	36.1°C
Working fluid inlet pressure	20 bars
Working fluid mass flowrate (Base)	10 kg/s
Working Fluids	Isopentane, n-pentane
Geofluids	Water, CO ₂

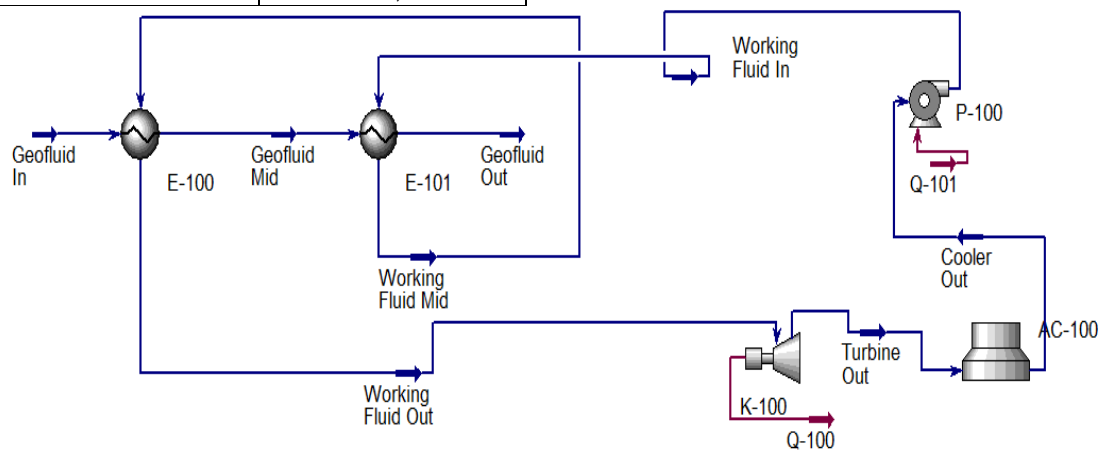

Figure 3. Process flow diagram (PFD) of the geothermal binary ORC system

Slika 3. Dijagram toka procesa (PFD) geotermalnog binarnog ORC sistema

Following figure 3, the geofluid coming from the well enters into HEX1 (E-100) and subsequently to HEX2 (E-101). The working fluid pumped into the heat exchangers extracted heat both from HEX2 and HEX1 and then exits HEX1 towards the turbine. At the turbine, the vapourized working fluid caused expansion which was used to rotate the turbine producing electricity. The electrical power was measured in kW at the turbine outlet. The working fluids exits the turbine at lower temperature and pressure and goes to the air cooler where it is cooled and then pumped back to the HEXs to continue the cycle. The Geofluid out from the outlet of HEX2 is injected back into the well and the cycle continues.

3.3. Sensitivity

The process model described above were conducted at base case and at varying process parameters highlighting the sensitivity of the

3.2. Process Simulation

The process was modelled using Aspen Hysys V11 software. The fluid property package used in the process was Peng Robinson's property package. The main process Hysys process components used includes the heat exchangers which were used to model the evaporators, the expander which was used to model the turbine, the air cooler which was used to model the condenser, and the pump. Two heat exchangers in series were used in the modelling. This was required to maximize the heat extraction from the geofluid. The process flow diagram (PFD) for the ORC process simulated in Hysys is given in figure 3.

process. Sensitivity analyses were conducted to investigate the effect of geofluid temperature, and working fluid flowrate. These formed the independent variables. The output results of the sensitivity included the electrical power generated and the max working fluid pressure. The two working fluids modelled were isopentane and n-pentane. These sensitivities were performed using water and CO₂ as geofluid-

4. RESULTS

Results of simulations are given and discussed in this section.

4.1. Results using water as geofluid

4.1.1. Effects of temperature on power generated

For water as geofluid, the effect of geofluid temperature on the electrical power produced using isopentane and n-pentane as working fluid is shown in figure 4.

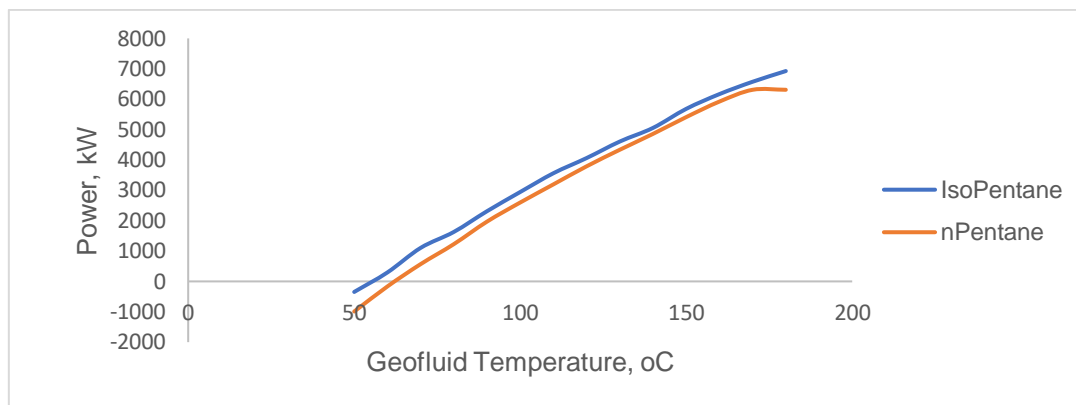

Figure 4. Effect of geofluid temperature on power produced using water as geofluid at 80 kg/s

Slika 4. Uticaj masenog protoka na proizvodnju energije korišćenjem vode kao geofluida na 100 °C

From figure 4, it can be seen that for both isopentane and n-pentane working fluids, the power produced increased as the water temperature is increased. This is expected as increase in temperature increases the thermal capacity of the geofluid, thus increasing its heat transfer to the working fluid for power production at the turbines. Furthermore, it can be observed that the use of isopentane working fluid resulted to higher electrical power generation at the turbine than n-pentane working fluid. Moreover, n-pentane showed negative power production when geofluid temperature was 60 °C while negative power production was observed for isopentane when the temperature of the water was 50 °C. It is seen that isopentane can handle lower temperatures than n-pentane at same operating conditions.

From the chart, at 80 kg/s mass flowrate of working fluid, the outlet power production from the turbine corresponding to isopentane and n-pentane working fluids at geofluid temperature of 180°C are 6924.8 kW and 6308 kW respectively. At this condition, it is seen that the use of isopentane as

working fluid increased the power production by 9.8%.

4.1.2. Effects of geofluid temperature on maximum pressure of working fluid for water geofluid

The maximum pressure denotes the range of operability for the working fluid used at the process conditions specified. Figure 4 shows the maximum pressure for isopentane and n-pentane working fluids corresponding to varying temperature of water geofluid investigated.

From figure 5, it can be seen that isopentane showed higher maximum pressure than n-pentane. These pressures affect the outlet temperature of the working fluid from the evaporator. At higher operable pressures, the working fluids exits the evaporator with higher temperatures which translates to higher power production. This highlights the advantage of isopentane as a better working fluid than n-pentane. However, as can be seen from the chart, at lower geofluid temperature, the differences in pressures between the two fluids widens.

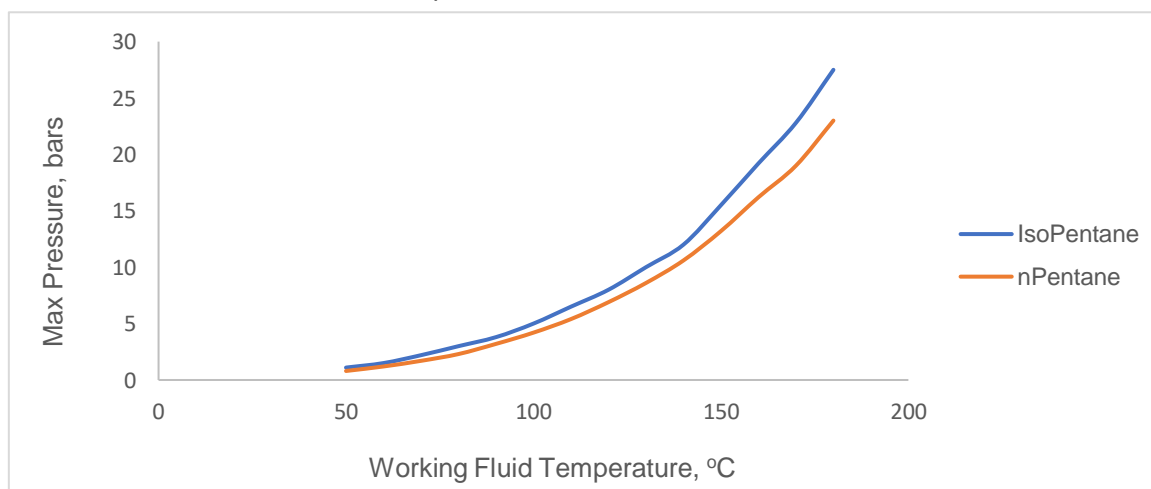

Figure 5. Maximum working fluid outlet pressure for water geofluid

Slika 5. Maksimalni izlazni pritisak radne tečnosti za vodeni geofluid

4.1.3. Effect of working fluid flowrate on power produced

The effect of the mass flowrate of the working fluids on the electrical power output of the turbine is given in this section.

The mass flowrates investigated were within the range of 1 to 100 kg/s at 100 °C. From figure 6, it can be seen that the mass flowrate of the working fluids yielded linearly proportionate increase with power production for both isopentane and n-pentane working fluids. Power increased as mass flowrate of working fluid increased. However, the rate of increase in power for isopentane was higher than that of n-pentane at corresponding mass flowrate of working fluids. Moreover, the nominal

differences in the power produced relative to the mass flowrates of the working fluids increased progressively as the mass flowrate increased although their percentage increased remained constant. For instance, at mass flowrate of 10 kg/s, the power generated using isopentane and n-pentane were 367.8 kW and 324.6 kW respectively which gave a nominal and percentage difference of 43.14 kW and 13.29% respectively. also, at mass flowrate of 100 kg/s, the power generated using isopentane and n-pentane were 3677.6 kW and 3246.3 kW respectively which gave a nominal and percentage difference of 431.4 kW and 13.29% respectively.

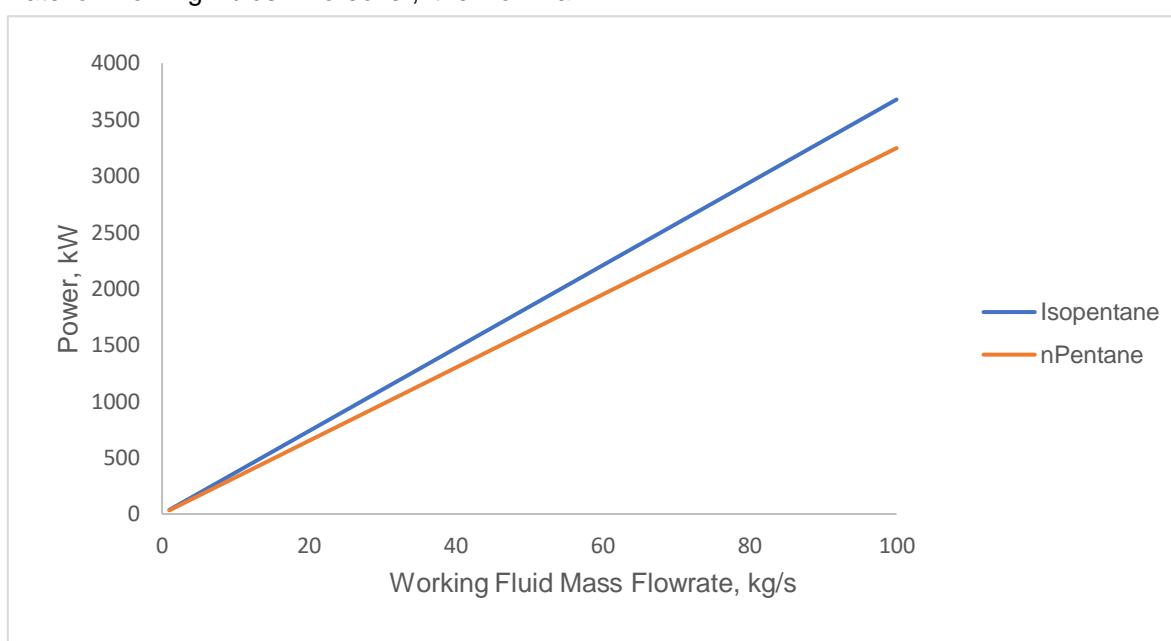

Figure 6. Effect of mass flowrate on power production using water as geofluid at 100°C

Slika 6. Uticaj masenog protoka na proizvodnju energije korišćenjem vode kao geofluida na 100°C

4.2. Results using CO₂ as geofluid

4.2.1. Effects of temperature on power generated

The effect of CO₂ geofluid temperature on the turbine outlet power generation is shown in Figure 7.

It is quickly observed from figure 7 that for CO₂ geofluid system, isopentane serves as a better working fluid than n-pentane demonstrated in the power produced relative to temperature. The power produced for both isopentane and n-pentane increased with increasing geofluid temperature. However, isopentane showed higher power output corresponding to each temperature increase compared to n-pentane. furthermore, it can be

seen from the chart, that CO₂ geofluid enable low-temperature binary system. Maximum operable temperature of the CO₂ geofluid was observed at 110°C. This implies that the usage of CO₂ as geofluid includes temperature ranges not greater than 110°C. At higher temperature, the process system. Moreover, isopentane showed better characteristics as a working fluid than n-pentane visible in the power generation. At 80 kg/s mass flowrate of working fluid, the outlet power production from the turbine corresponding to isopentane and n-pentane working fluids at geofluid temperature of 110°C are 3738.4 kW and 3448 kW respectively. At this condition, it is seen that the use of isopentane as working fluid increased the power production by 8.4%.

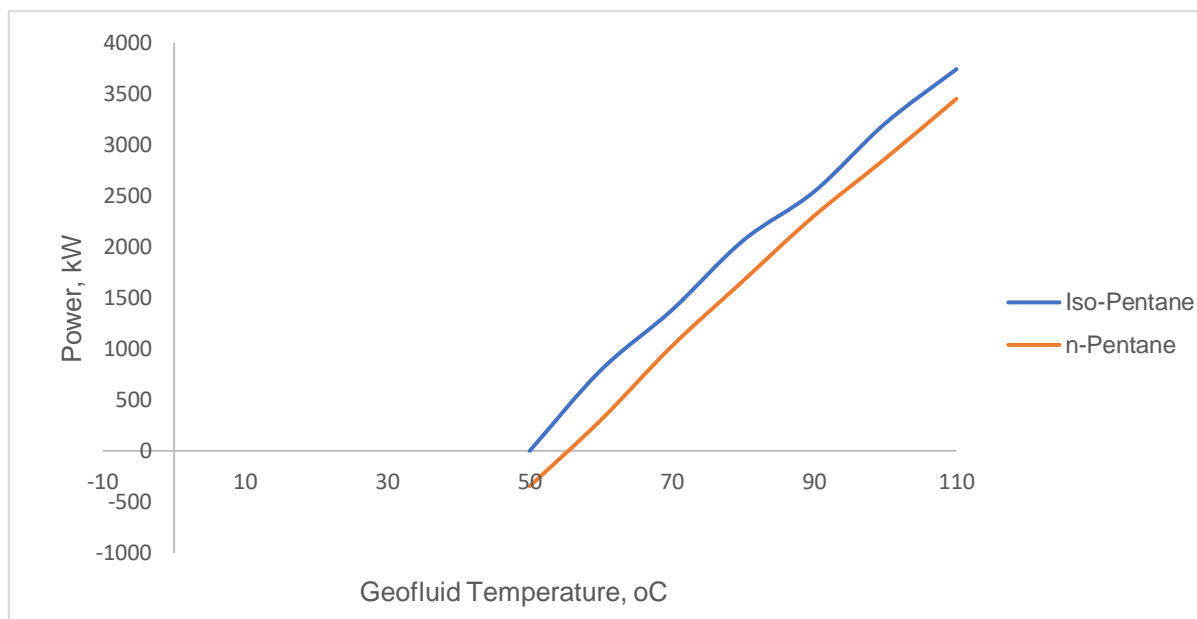

Figure 7. Effect of geofluid temperature on power produced using CO₂ as geofluid at 80 kg/s

Slika 7. Uticaj temperature geofluida na snagu proizvedenu korišćenjem CO₂ kao geofluida pri 80 kg/s

4.2.2. Effects of geofluid temperature on maximum pressure of working fluid for CO₂ geofluid

Figure 8 shows the maximum pressure for isopentane and n-pentane working fluids corresponding to varying temperature of CO₂ geofluid investigated.

From figure 8, it can be seen that isopentane showed higher maximum pressure than n-pentane

when used with CO₂ geofluid. At higher operable pressures, the working fluids exits the evaporator with higher temperatures which translates to higher power production. This shows the advantage of isopentane as a better working fluid than n-pentane. However, as can be seen from the chart, at lower geofluid temperature, the differences in pressures between the two fluids widens.

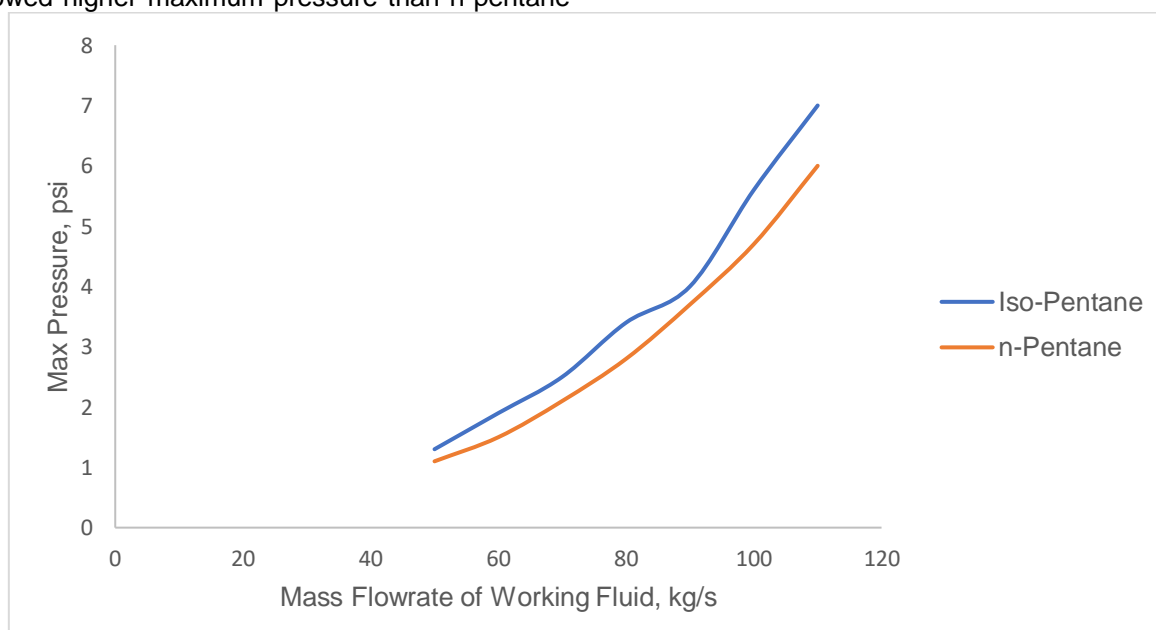

Figure 8. Maximum Working Fluid Outlet Pressure for Water geofluid

Slika 8. Maksimalni izlazni pritisak radne tečnosti za vodeni geofluid

4.2.3. Effect of Working Fluid Flowrate on Power Produced

The effect of the mass flowrate of the working fluids on the electrical power output of the turbine is given in this section.

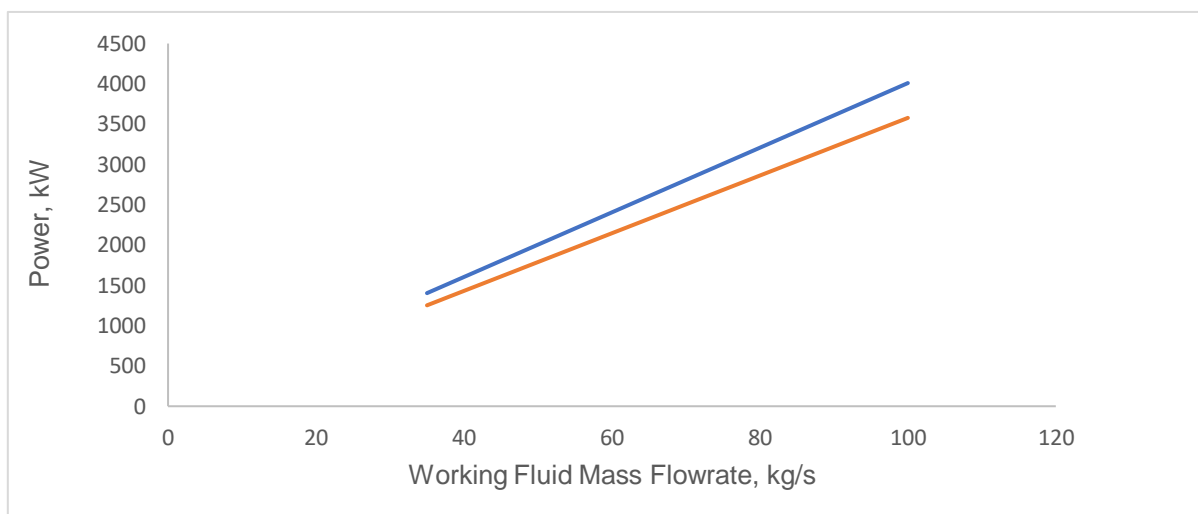

Figure 9. Effect of mass flowrate on power production using CO₂ as geofluid at 100 °C

Slika 9. Uticaj masenog protoka na proizvodnju energije korišćenjem CO₂ kao geofluida na 100 °C

From figure 9, it can be observed that the power produced increased linearly with mass flowrate for both isopentane and n-pentane working fluids. However, the power generated for isopentane working fluid was higher than that of n-pentane at corresponding mass flowrates. At mass flowrate of 10 kg/s, the power generated using isopentane and n-pentane were 4009.7 kW and 3577.9 kW respectively. This gave a nominal and percentage difference of 43.18 kW and 12.07 % respectively. Furthermore, at mass flowrate of 100 kg/s, the power generated using isopentane and n-

pentane were 3677.6kW and 3246.3kW respectively which gave a nominal and percentage difference of 431.4 kW and 12.07 % respectively

4.2.4. Comparison of Water and CO₂ as geofluids

Comparison of the simulation results is made relative to water and CO₂ as geofluids.

Figure 9 shows the effect geofluid temperature on power production using water and CO₂ geofluids.

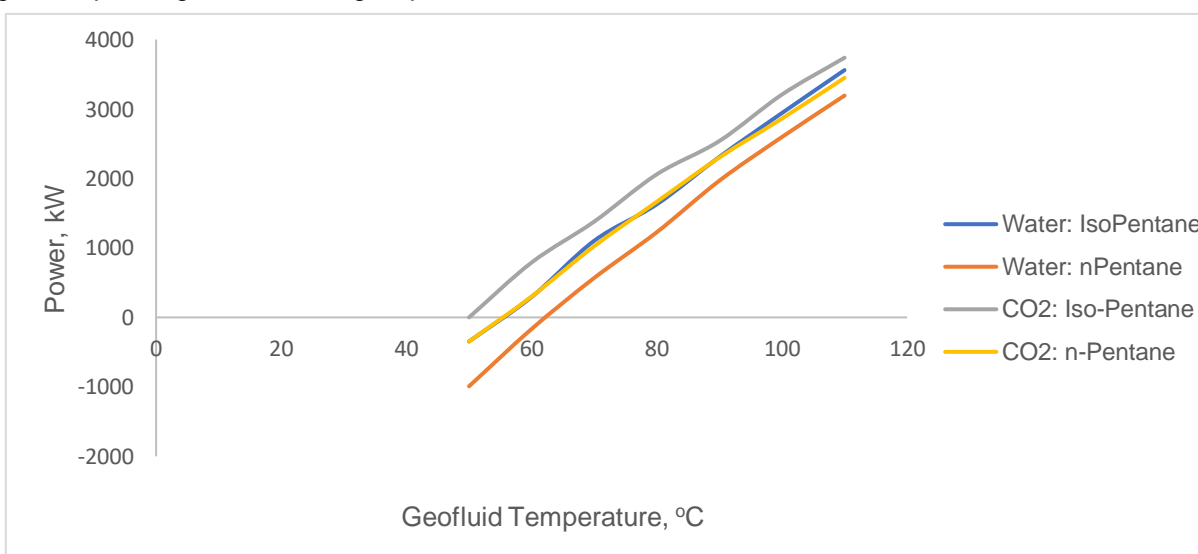

Figure 10. Effect of Geofluid on power production using water and CO₂ geofluids

Slika 10. Uticaj Geofluida na proizvodnju energije korišćenjem vode i CO₂ geofluida

From figure 10, it can be observed that the power produced from CO₂ geofluid is significantly higher than that of water at all geofluid temperatures. This was observed for both isopentane and n-pentane working fluids respectively. The comparison was made for geofluids temperatures within the range of 50 °C to 110 °C. This was necessary since the CO₂ geofluid showed maximum temperature operability at 110 °C. At 110 °C, the power produced using water geofluid at 80kg/s mass flowrate are 3560.8 kW and 3193.6 kW for isopentane and n-pentane working fluids respectively while the power produced at the same conditions for CO₂ geofluids are 3738.4 kW and 3448 kW for isopentane and n-pentane working fluids respectively. CO₂ geofluid showed 5% and 8% higher power generation than water for isopentane and n-pentane working fluids respectively. CO₂ proves a better geofluid than water for geothermal heat exploitation for low-temperature geothermal systems.

CO₂ has been selected as geofluid to its high compressibility, expansivity and low viscosity in comparison to water. However, CO₂ is feasible at lower temperatures, transferring geothermal heat more efficiently than water. Using CO₂ as working fluid fosters the utilization of low-temperature geothermal systems enabling the widespread adoption of the renewable resource.

4.3. Discussion

The study presented the modelling of a binary Organic Rankine Cycle (ORC) system used for electricity generation using geothermal fluids. Heat from a geothermal reservoir to generate power using water and CO₂ as the heat extraction fluids (geofluids). The geothermal fluid is sent to an evaporator where it heats the working fluid, causing it to vaporize and subsequently to produce electricity in the turbine. Two working fluids, isopentane and n-pentane, were considered, and simulations were conducted using both water and CO₂ as geofluids. A complete thermodynamic modelling and simulation of the process was conducted in Aspen Hysys. The process, environmental and economic aspect of the study are discussed.

4.3.1. Process Consideration

From the results on the effects of geofluid temperature on power generation, it was observed that power generation increased with higher geofluid temperature. This aligns with the basic principles of thermodynamics. As the geofluid temperature rises, it carries more thermal energy, leading to increased heat transfer to the working fluid in the evaporator. This results in higher

vaporization and subsequently greater expansion in the turbine, generating more power. This phenomenon is well-established in heat-to-power conversion processes.

Furthermore, it was observed that isopentane showed higher power generation compared to n-pentane at all geofluid temperatures. The results can be attributed to the distinct thermodynamic properties of isopentane and n-pentane. Isopentane has higher boiling point, specific heat capacity, and vaporization than n-pentane. These characteristics contribute to its superior performance enhancing its ability to absorb heat from the geofluid, resulting in more efficient vaporization and expansion in the turbine.

It was also observed that Isopentane could handle lower temperatures than n-pentane. The ability of isopentane to handle lower temperatures ranges highlights its usage in the design and exploitation of wider range of geothermal resources.

It was observed that Isopentane generally exhibited higher maximum pressure than n-pentane, indicating a better performance in terms of operability. Higher maximum pressures indicate the working fluid's capacity to expand more in the turbine, which translates to greater mechanical work done, hence higher power output. Furthermore, higher pressure allowed the working fluid to exit the evaporator at higher temperatures, resulting in higher power generation.

Furthermore, it was observed from the results that power generation increased linearly with the mass flow rate of the working fluids. Higher mass flowrates of the working fluids translate to higher heat energy extraction from the geofluid resulting to increased power generation. Isopentane had a higher rate of increase in power compared to n-pentane at the same mass flow rate which as has been demonstrated highlights its much-enhanced thermodynamic properties.

CO₂ geofluid performed better than water geofluid in terms of power generation across various geofluid temperatures. CO₂ possess higher compressibility and expansivity, lower viscosity compared to water, which makes it a more efficient heat transfer fluid. The maximum operable temperature for CO₂ geofluid which was observed at 110°C suggests that CO₂ is well-suited for low-temperature geothermal systems. Thus, CO₂ characteristics as a geofluid enable the utilization of low-temperature geothermal resources. Due to its specific heat capacity and compressibility, CO₂ can efficiently transfer heat at the lower temperatures.

4.3.2. Environmental Considerations

The results indicate that CO₂ can lead to higher power generation and efficiency in low-temperature geothermal systems. This is important when environmental consideration is paramount, as increased process efficiency translates to higher power output from the same amount of heat. This potentially reduces the need for additional heat extraction, thus minimizing the environmental impact on geothermal reservoirs. Furthermore, the use of CO₂ as geofluid in geothermal systems aligns with the broader goals of reducing greenhouse gas emissions and transitioning to cleaner energy sources. The thermodynamic properties of CO₂ contribute to better heat transfer between the geothermal reservoir and the working fluid, potentially reducing the need for aggressive reservoir stimulation thus inducing positive implications for maintaining reservoir integrity and minimizing induced seismicity potentially widespread with water as geofluid.

On the other hand, while water is a natural choice for geofluid, its extraction and reinjection could have local environmental effects. Altering the temperature and pressure of the geothermal reservoir can affect the subsurface ecosystem, potentially impacting local ecosystems and water resources. Water might not be as efficient as CO₂ in low-temperature geothermal systems, which could lead to a higher environmental footprint. Extracting more water from the reservoir to achieve the desired power output might have greater ecological consequences.

4.3.3. Economic Considerations

In terms of economics, while the potentials of CO₂ for higher power output translates to more revenue from electricity sales, CO₂ project has more complex designs requiring higher upfront investment and operational costs than water. Also, the use of water as geofluid has reduced uncertainty during project implementation. Water extraction and reinjection regulations can vary by region. If local regulations favour water use over CO₂, this might influence the economic feasibility of geothermal projects. However, the characteristics of CO₂ for low-temperature geothermal resource exploitation expands the potential for geothermal power generation, maximizing resource utilization and potentially attracting more investment. Thorough economic investigation of CO₂ and water as geofluid in geothermal resource extraction would aid decision process in the choice of the geothermal heat extraction fluid.

5. CONCLUSION

This study presented a comprehensive analysis of a binary Organic Rankine Cycle (ORC) system for electricity generation using geothermal fluids as heat sources and hydrocarbon fluids as working fluids. Isopentane and n-pentane were used as the working fluid for binary system turbine electricity generation. The study focused on the comparison between water and CO₂ as geofluids, assessing their impacts on power generation, efficiency, and operability.

Base on process considerations from the simulation performed, both isopentane and n-pentane geofluids exhibited thermodynamic behaviour that showed theoretical correlations. Higher geofluid temperatures led to increased power generation, attributed to the greater heat transfer and subsequent vaporization of the working fluid in the evaporator. Isopentane consistently outperformed n-pentane due to its better thermodynamic properties, resulting in higher power output and broader operational temperature range.

CO₂ as a geofluid demonstrated significant advantages, highlighting its potential as a more efficient heat transfer medium compared to water. The unique characteristics of CO₂, such as high compressibility, expansivity, and low viscosity, translated to higher power generation. This is particularly significant for enabling the utilization of low-temperature geothermal resources, which is critical for sustainable geothermal energy development.

Environmental considerations highlighted CO₂'s alignment with clean energy goals, contributing to reduced emissions and better reservoir management. Additionally, CO₂'s potential for lower seismic impact due to enhanced heat transfer characteristics is a positive aspect in terms of reservoir integrity and induced seismicity.

Economically, the choice between CO₂ and water as geofluids involves a trade-off. While CO₂ presents the potential for higher power output and revenue generation, it also entails more complex system designs and potentially higher upfront investments. Water, being a well-established geofluid, offers simpler project implementation and operational advantages but might have limitations in terms of efficiency and resource utilization. Further research on economic evaluations were suggested as it is essential to fully determine the feasibility and sustainability of using CO₂ as a geofluid for geothermal heat extraction.

6. REFERENCES

- [1] A.Sowiżdżał, W.Górecki, M.Hajto (2020) Geological conditions of geothermal resource occurrences in Poland. *Geological Quarterly*, 64(1), 185-196.
- [2] P.Ziółkowski, R.Hyrzyński, M.Lemański, B.Kraszewski, S.Bykuć, S.Głuch, J.Badur (2021) Different design aspects of an Organic Rankine Cycle turbine for electricity production using a geothermal binary power plant. *Energy Conversion and Management*, 246, 114672.
- [3] P.Ziółkowski, T.Kowalczyk, M.Lemański, J.Badur (2019) On energy, exergy, and environmental aspects of a combined gas-steam cycle for heat and power generation undergoing a process of retrofitting by steam injection. *Energy Conversion and Management*, 192, 374-384.
- [4] R.Hyrzyński, P.Ziółkowski, S.Gotzman, B.Kraszewski, T.Ochrymiuk, J.Badur (2021) Comprehensive thermodynamic analysis of the CAES system coupled with the underground thermal energy storage taking into account global, central and local level of energy conversion. *Renewable Energy*, 169, 379-403.
- [5] J.Badur, M.Lemański, T. Kowalczyk, P. Ziółkowski, S. Kornet (2018) Zero-dimensional robust model of an SOFC with internal reforming for hybrid energy cycles. *Energy*, 158, 128-138.
- [6] M.Kantorek, K.Jesionek, S.Polesek-Karczewska, P.Ziółkowski, M.Stajne, J.Badur (2021) Thermal utilization of meat-and-bone meal using the rotary kiln pyrolyzer and the fluidized bed boiler–The performance of pilot-scale installation. *Renewable Energy*, 164, 1447-1456.
- [7] A.Wachowicz-Pyzik, A.Sowiżdżał, L.Pająk, P.Ziółkowski, J.Badur (2020) Assessment of the Effective Variants Leading to Higher Efficiency for the Geothermal Doublet, Using Numerical Analysis–Case Study from Poland (Szczecin Trough). *Energies*, 13(9), 2174.
- [8] X.Dai, L.Shi, W.Qian (2019) Thermal stability of hexamethyldisiloxane (MM) as a working fluid for organic Rankine cycle. *International Journal of Energy Research*, 43(2), 896-904.
- [9] P.Niknam, L.Talluri, D.Fiaschi, G.Manfrida (2021) Sensitivity analysis and dynamic modelling of the reinjection process in a binary cycle geothermal power plant of Larderello area. *Energy*, 214, 118869.
- [10] A.Sowiżdżał (2018) Geothermal energy resources in Poland–Overview of the current state of knowledge. *Renewable and Sustainable Energy Reviews*, 82, 4020-4027.
- [11] M.Kaczmarczyk, B.Tomaszewska, L.Pająk (2020) Geological and thermodynamic analysis of low enthalpy geothermal resources to electricity generation using ORC and Kalina cycle technology. *Energies*, 13(6), 1335.
- [12] M.Pasetti, C.Invernizzi, P.Iora (2014) Thermal stability of working fluids for organic Rankine cycles: An improved survey method and experimental results for cyclopentane, isopentane and n-butane. *Applied Thermal Engineering*, 73(1), 764-774.
- [13] M.Ashouri, M.Ahmadi, M.Feidt (2014) Performance analysis of organic Rankine cycle integrated with a parabolic through solar collector. In *Conference paper. The 4th World Sustainability Forum*.
- [14] M.Salman, J.Hennessy, H.Li (2017) Evaluating the Organic Rankine Cycle (Orc) for Heat to Power. Book, Publication: Malardalens Universitet.
- [15] Y.Najjar, A.Qatramez (2019) Energy utilisation in a combined geothermal and organic Rankine power cycles. *International Journal of Sustainable Energy*, 38(9), 831-848.
- [16] R.Wang, L.Jiang, Z.Ma, A.Gonzalez-Diaz, Y.Wang, A.Roskilly (2019) Comparative analysis of small-scale organic Rankine cycle systems for solar energy utilisation. *Energies*, 12(5), 829.
- [17] Y.Wang, J.Song, M.Chatzopoulou, N.Sunny, M.Simpson, J.Wang, C.Markides (2021) A holistic thermoeconomic assessment of small-scale, distributed solar organic Rankine cycle (ORC) systems: Comprehensive comparison of configurations, component and working fluid selection. *Energy Conversion and Management*, 248, 114618.
- [18] J.Song, P.Loo, J.Teo, C.Markides (2020) Thermo-economic optimization of organic Rankine cycle (ORC) systems for geothermal power generation: A comparative study of system configurations. *Frontiers in Energy Research*, 8, 6.
- [19] J.Song, Y.Wang, K.Wang, J.Wang, C.Markides (2021) Combined supercritical CO₂ (SCO₂) cycle and organic Rankine cycle (ORC) system for hybrid solar and geothermal power generation: Thermoeconomic assessment of various configurations. *Renewable Energy*, 174, 1020-1035.
- [20] A.Sowiżdżał, B.Papiernik, G.Machowski, M.Hajto (2013) Characterization of petrophysical parameters of the Lower Triassic deposits in prospective location for Enhanced Geothermal System (central Poland). *Geological Quarterly*, 57, 729-744.

- [21] K.Barse (2014) *Design and optimization of organic rankine cycle for low temperature geothermal power plant*. The University of North Dakota.
- [22] M. Bahrami, F. Pourfayaz, A. Kasaeian (2022) Low global warming potential (GWP) working fluids (WFs) for Organic Rankine Cycle (ORC) applications. *Energy Reports*, 8, 2976-2988.
- [23] H.D.Venomhata, P.Oketch, B.Gathitu, P. Chisale (2023) Working fluid selection for the geothermal-solar hybrid cycle at Olkaria II power plant in Kenya. *Heliyon*, 9(1), 1-15.
- [24] C.Choudhari, S.Sapali (2017) Performance investigation of natural refrigerant R290 as a substitute to R22 in refrigeration systems. *Energy Procedia*, 109, 346-352.
- [25] B.Keçińska (2019) Geothermal energy use—Country update for Poland, 2016–2018. In *European Geothermal Congress*.

IZVOD

KOMPARATIVNA ANALIZA GEOTERMALNIH BINARNIH ORC SISTEMA: PERFORMANSE I RAZMATRANJA ŽIVOTNE SREDINE ZA CO₂ I VODU KAO GEOFLUIDE

Ova studija razmatra simulaciju procesa geotermalnih binarnih sistema organskog Rankinovog ciklusa (ORC) koji koriste CO₂ i vodu kao geofluide za proizvodnju električne energije. Simulacija je izvedena korišćenjem softvera Hisis v11 korišćenjem Peng Robinsonovog paketa fluidnih svojstava. Korišćene su dve suve radne tečnosti uključujući izopentan i n-pentan. Ocenjeni su uticaji temperature geofluida i masenog protoka radnog fluida na proizvodnju električne energije, kao i maksimalnog pritiska radnih fluida. Rezultat je pokazao da se proizvodnja energije povećava sa višom temperaturom geofluida zbog poboljšanog prenosa toplote. Izopentan je nadmašio n-pentan, što se pripisuje njegovim superiornim termodinamičkim svojstvima. CO₂ je pokazao bolje performanse kao geofluid od vode, naglašavajući njegovu superiornost, primećenu u povećanju proizvodnje energije. Jedinstvene karakteristike CO₂ omogućavaju efikasan prenos toplote na nižim temperaturama, što ga čini ekološki prihvatljivim i efikasnim izborom. Nasuprot tome, upotreba vode kao geofluida predstavlja neke implikacije za lokalne ekosisteme i vodne resurse. Iz perspektive životne sredine, CO₂ pokazuje veći potencijal za smanjenje uticaja na životnu sredinu, što je u skladu sa prelaskom na čistije izvore energije. Međutim, ekonomska razmatranja sugerišu kompromis, jer projekti CO₂ mogu dovesti do većih početnih troškova u poređenju sa sistemima zasnovanim na vodi. Regulatorni faktori i ekonomska izvodljivost, stoga, igraju ključnu ulogu u izboru geofluida za proizvodnju geotermalne energije.

Ključne reči: Geofluid, radni fluid, ORC, obnovljiva energija

Naučni rad

Rad primljen: 21.09.2023.

Rad prihvaćen: 07.10.2023.

Rad je dostupan na sajtu: www.idk.org.rs/casopis