

MILICA GVOZDENOVIĆ<sup>1</sup>, BRANIMIR JUGOVIĆ<sup>2</sup>,  
DALIBORKA JAMBREC<sup>3</sup>, JASMINA STEVANOVIĆ<sup>4</sup>,  
BRANIMIR GRGUR<sup>1</sup>

Scientific paper  
UDC:620.193.667.28

## Application of polyaniline in corrosion protection of metals

*Polyaniline is probably the most investigated electroconducting polymer. This popularity is a result of its important features: existence of various oxidation states, electrical and optical activity, low cost monomer, red/ox reversibility, environmental stability, ease of both chemical and electrochemical synthesis etc. These unique features are partly inherited from its polymeric origin and partly aroused from its conductivity and could be considered for practical application in: electrochemical systems for energy storage and conversion, electronic devices, electromagnetic and microwave shielding materials, sensors, biosensors and corrosion protection as well. The motivation of application of polyaniline in corrosion protection of metals and alloys is replacement of environmentally hazardous materials, e.g. chromates in coating systems. Up to day, lot of studies on various metals both on iron, steels and non-ferrous metals and alloys were performed. The studies involve investigation on individual polyaniline coatings and polyaniline in coating systems. Owing to variation in experimental procedure (substrate, substrate preparation, coating type, corrosion environment, test method etc..) it is unlikely to propose unique mechanism for corrosion protection of metals in the presence of polyaniline. However, most of the literature is interpreted in terms of general mechanisms of corrosion protection, barrier and anodic protection.*

**Key words:** electroconducting polymers, polyaniline, coatings, corrosion protection

### 1. INTRODUCTION

Polyaniline is an eldest electroconducting polymer, known for over a century, since so called aniline blacks were used as cotton dyes in textile industry [1]. Until the discovery of its conductivity, in the form of emeraldine salt, only sporadic studies of this unique material were taken. From that time, and up to day, polyaniline is the most studied among numerous conducting polymers. There is a still growing interest in polyaniline investigation as seen in Fig. 1. (data estimated from Science Direct only).

Such popularity of polyaniline, in both theoretical and practical aspects, is due to its unique properties: low cost monomer, possibility of chemical and electrochemical synthesis, electrochemical activity, optical activity, stability, etc, representing good prerequisite for the practical application, as seen in Fig.2, where distribution of papers dedicated to practical application of polyaniline is given.

Author's address: <sup>1</sup>Faculty of Technology and Metallurgy, University of Belgrade, Karnegijeva 4, Belgrade, Serbia, <sup>2</sup>Institute of Technical Sciences SASA, Knez Mihajova 35, Belgrade, Serbia, <sup>3</sup>Innovation Center, Faculty of Technology and Metallurgy, University of Belgrade, Karnegijeva 4, Belgrade, Serbia, <sup>4</sup>Institute of Chemistry Technology and Metallurgy, University of Belgrad, Njegoševa 12, Belgrade, Serbia

Paper received: 19. 09. 2012.

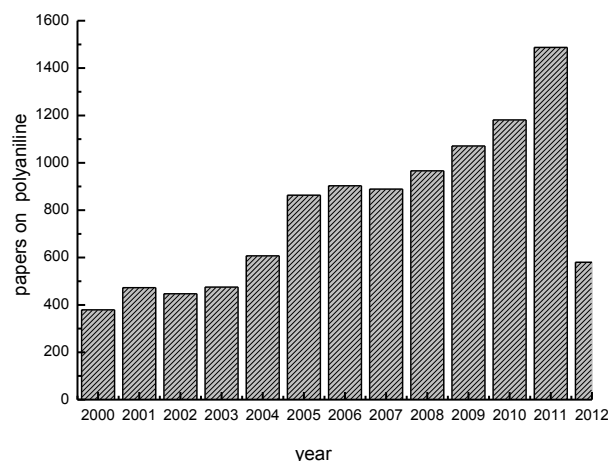

Figure 1 - Number of publication in journals (Science Direct) related to polyaniline.

As it could be seen in Fig.2. application of polyaniline in corrosion protection of metals and alloys is very important subject. The motivation for application of polyaniline in corrosion protection stems from the environmental requirement for replacement of toxic layers, mainly chromates, from coating systems. Application of polyaniline in corrosion protection involves both individual coatings, or application as a primer layer in a coating system.

Coating by polyaniline is usually achieved by direct deposition from solvents, by electrochemical deposition, or by coating with various commercial coatings (epoxy, polyester, acrylic, polyurethane...)

containing polyaniline powders [2, 3]. Polyaniline can be obtained by both chemical and electrochemical oxidative polymerization of aniline monomer [4-7]. Chemical polymerization is used when large quantities of polymer are required, to date; it has been the major commercial method of polyaniline preparation. Electrochemical polymerization allows direct deposition of polyaniline in the form of coating, facilitating further analysis. On the other hand, electrochemical synthesis can also be useful for production of polyaniline powder [7].

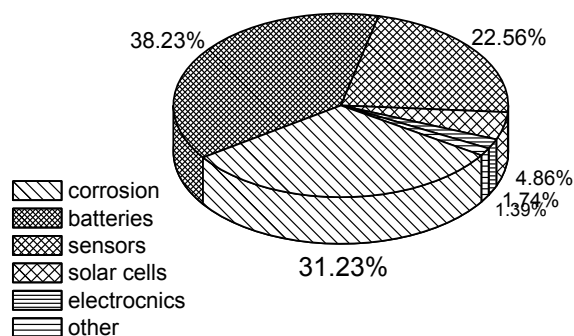

Figure 2 - Scientific papers published on application of polyaniline categorized into various topics.

Although easily performed on inert anodes, electrochemical synthesis of polyaniline faces problems when deposition is required on active metals, since the potentials, necessary for oxidation of aniline

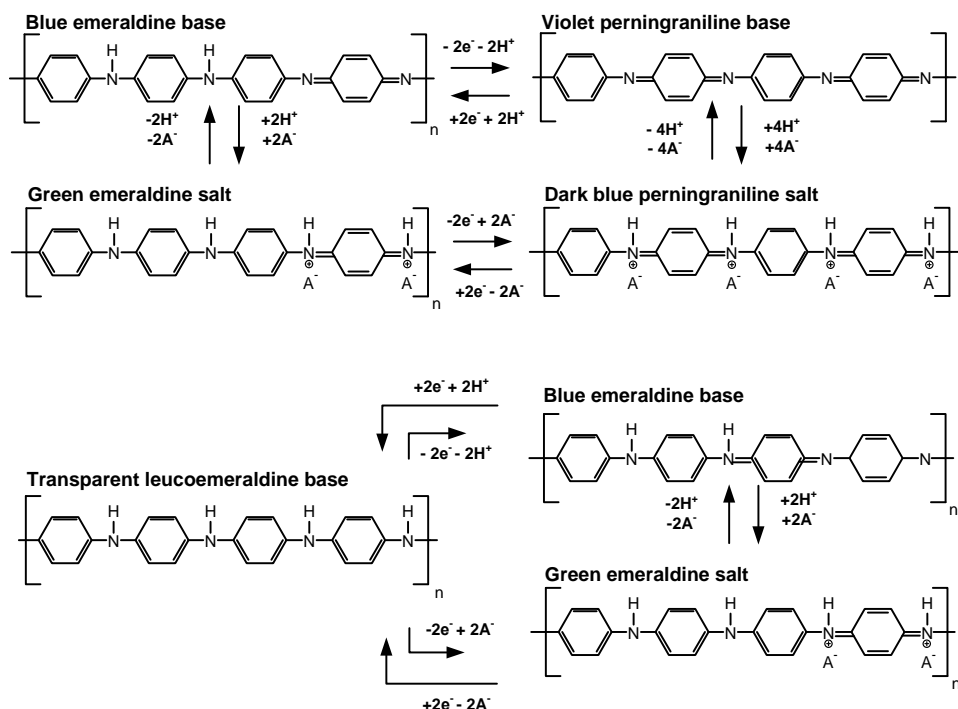

Figure 3 - Different forms of polyaniline, and its mutual conversions.

monomer, are high and provokes either dissolution, or formation of non-conducting passive layers on active metals.

The comprehensive insight into the mechanisms of corrosion protection of metals by polyaniline is very difficult owing to the variations in experimental approach, involving different coating types, metal preparation prior to coating, differences in both composition of corrosion environment and test methods etc. Most of the literature is interpreted relying to classical mechanism of corrosion protection, although some alternative mechanisms were also reported, especially in the case of iron and steels [2, 3, 8, 9].

## 2. POLYANILINE

The unique property of polyaniline, unlike all other electroconducting polymers, is existence in different forms depending on degree of oxidation, known as: leucoemeraldine, emeraldine and perningraniline. Leucoemeraldine, eg. leucoemeraldine base, refers to fully reduced form; emeraldine, eg. Emeraldine base, is half-oxidized, while perningraniline, eg. perningraniline base, is completely oxidized form of polyaniline. The most conducting form of polyaniline is emeraldin salt, obtained by doping or protonation of emeraldine base [8].

The mentioned polyaniline forms can be easily mutually converted by both chemical and electrochemical reactions, as seen in Figure 3 [6,9].

Apart from the changes in oxidation levels, all the transitions among polyaniline forms are manifested by color and conductivity changes. The conducting protonated emeraldine in the form of green emeraldine salt, obtained as a product of both chemical and electrochemical polymerization of aniline in acidic electrolytes, can be easily transformed by further oxidation to fully oxidized dark blue pernigraniline salt, which can be treated by alkali to form violet pernigraniline. Emeraldine salt can also be reduced to transparent leucoemeraldine, or can be transformed by alkali to blue non conducting emeraldine. Both reduction of emeraldine salt to leucoemeraldine and oxidation to pernigraniline states are followed by decrease in conductivity [9]. The existence of polyaniline in various oxidation forms and knowledge on its mutual transformations is of great importance for the interpretation of possible corrosion protection mechanisms. Fact that polyaniline possess redox activity, and that relative electrode potential of polyaniline, as seen in Table 1. is greater than those of active metals, alloys and chromate couple, implies its beneficial interaction with active metals and alloys altering their corrosion behavior [2]

Table 1 - Relative electrode potentials for different redox couples involved in corrosion

Redox couple	$E_r$ (vs. SHE at pH 7)
Fe/Fe <sup>2+</sup>	-0.62
Zn/Zn <sup>2+</sup>	-0.76
Al/Al <sub>2</sub> O <sub>3</sub>	-1.96
Mg/Mg <sup>2+</sup>	-2.36
CrO <sub>4</sub> <sup>2-</sup> /Cr <sub>2</sub> O <sub>3</sub>	0.42
POLYANILINE	0.60 - 1.0

The actual reduction potential of aniline can not be provided, since it depends on identity of dopant anion. The potentials given in Table 1 indicate that the mechanism of corrosion protection of active metals and alloys is likely to involve anodic protection, as it will be discussed later.

### 3. SYNTHESIS OF POLYANILINE

Polyaniline is commonly obtained by chemical or electrochemical oxidative polymerization of aniline, although photochemically initiated polymerization and enzyme catalyzed polymerization was also reported. Polyaniline obtained by electrochemical polymerization is usually deposited on the electrode, however electrohydrodynamic route was also developed resulting in polyaniline colloids of specific functionalities [10].

For the purposes of corrosion protection, polyaniline, obtained by chemical polymerization, is used in the form of powders lately mixed into common binders, or polyaniline is deposited or from organic solvents (usually toluene or *N*-methyl-2-pyrrolidone). Similarly, electrochemical synthesis is used for direct deposition onto metals and alloys, but electrochemical synthesis can also be used for production of polyaniline powder. The mechanism of chemical and electrochemical synthesis procedures is quite similar, involving redox initiated formation of radical cation. The advantage of electrochemical synthesis is avoidance of usage of oxidants, while the advantage of chemical synthesis is capability of obtaining large quantities of polyaniline. Commercially available, products for corrosion protection, based on polyaniline, such as: Versicon®, CorrPassiv® or PANDA®, all uses polyaniline obtained by chemical synthesis [2].

#### 2.1. Chemical synthesis

Chemical synthesis of polyaniline requires oxidizing force supplied by chemical oxidant (redox initiator). The most widely employed oxidant is (NH<sub>4</sub>)<sub>2</sub>S<sub>2</sub>O<sub>8</sub>, but other oxidants can also be used such as: FeCl<sub>3</sub>, Ce(SO<sub>4</sub>)<sub>2</sub>, K<sub>2</sub>Cr<sub>2</sub>O<sub>7</sub>, H<sub>2</sub>O<sub>2</sub> etc. [11].

Strong acidic solution is required for assist the solubilization of aniline and to avoid formation of low molecular weight oligomers and branching [4,5]. The chemical polymerization of aniline proceeds according to schematic presentation in Figure 4.

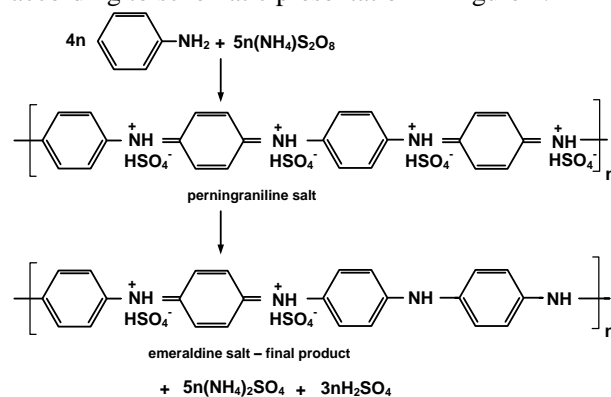

Figure 4 - Chemical synthesis of polyaniline

As seen in Fig.4., the final product of chemical polymerization of aniline is green conductive emeraldine salt. Polyaniline in the form of emeraldine salt is either directly used for corrosion protection, or converted to emeraldine base.

#### 2.2. Electrochemical synthesis

Electrochemical synthesis is useful for coating of metals to be protected, but it can be also useful for obtaining powders, lately mixed into commercial

protective coatings. As stated before, the main advantage of electrochemical synthesis is avoidance of oxidants, leading to a high purity product. Direct deposition of polyaniline onto so called inert anodes, such as: graphite, Pt, various carbons, ITO glass etc. is easy to perform. The electrolyte is consisted of aqueous solution of aniline monomer and acid. The polymerization of aniline proceeds together with insertion of anions (dopants) originated from the acid, according to:



Where  $y$  refers to doping degree, ratio between the number of charges in the polymer and the number of monomer units [12].

In order to produce powders of polyaniline, electrochemical polymerization is performed on graphite plates (anode) in aqueous acidic electrolytes, and the polymer product is peeled of the electrode and lately transformed to emeraldine or eleraldine salt.

Since the potential required for initiation of aniline polymerization is high ( $\sim 0.9$  V) direct deposition of polyaniline on metals and alloys to be protected, is faced to specific problems of, either metal dissolution, or formation of low conductive oxides at the potentials required for oxidation of aniline monomer [13-17]. These problems can be overcome by the proper choice of electrolyte, or by surface pre-treatment.

Electrolyte has to meet the requirement of passivating the metal with non insulating passive (or pseudo-passive) film that could enable further undisturbed deposition of polyaniline.

The most popular electrolyte for electrochemical deposition of polyaniline on steel, aluminum its alloys, copper and brass is doubtless oxalic acid. The formation of pseudo-passive film based on oxalate is evidenced, enabling efficient deposition of polyaniline [2]. Recently, it was observed that aqueous electrolyte containing aniline and sodium-benzoate can be used for galvanostatic electrochemical synthesis of protective polyaniline on mild steel, aluminum and copper as well [3, 15-17].

The surface pre-treatment involves either deposition of electroconducting polymer obtained from easily oxidized monomer e.g. polypyrrole, after which the deposition of polyaniline was facilitated, or pre-treatment with some chelating agent.

Polyaniline was impossible to grow onto zinc electrode from acidic electrolyte containing aniline monomer. Camalet et al. was observed that aniline was easily polymerized onto zinc from acidic aqueous electrolyte onto previously deposited thin layer of polypyrrole. The polypyrrole pretreatment was chosen

since the potential required for initiation of the pyrrole monomer polymerization is significantly lower [13].

Other approach involves used of chelating agents, such as alizarine [14]. The use of chelating agents is common procedure in the electroplating industry. With respect to its nature, which can be hydrophilic or hydrophobic, chelating agent can lead to passivation of the metal by a salt, or by a blocking compound. Alizarin is hydrophobic type chelating agent, and its role is explained by the formation of more than one coordinate bond with a metal and by suppressing of the hydrogen evolution reaction by blocking the metallic surface for hydrogen adsorption [18].

The common experimental techniques used for electrochemical polymerization of aniline are: cyclic voltammetry (potentiodynamic), galvanostatic and potentiostatic techniques. Polymerization using cyclic voltammetry is characterized by cyclic regular change of the electrode potential and the deposited polymer is, throughout the experiment, changing between its non-conducting and conducting (doped) state, followed by exchange of the electrolyte through polymer [19]. Potentiostatic technique provides polymerization at constant potential, this technique is less used since the potential required for initiation of the aniline polymerization, as already stated, is high, which can lately caused overoxidation of the film and formation of degradation products. Galvanostatic technique enables polymerization to occur at constant rate (current), so the mass or thickness of the polymer can be adjusted by altering the polymerization time.

#### 4. CORROSION PROTECTION IN THE PRESENCE OF POLYANILINE

It is experimentally evidenced that polyaniline was efficient in corrosion protection of active metals and their alloys. The literature dealing with protective features of polyaniline is extremely rich; polyaniline is applied in the form of individual coating or as a component of a coating system. Owing to variety of materials, corrosion environments, differences in coating procedure and coating types, different substrate pre-treatments, and differences in testing methods, it is practically impossible to establish the unique mechanism of corrosion protection in the presence of polyaniline based coatings. Moreover, there are contradictory reports on which form, emeraldine base or emeraldine salt provides better protection [2].

##### 4.1. Experimental techniques

The estimation of protective properties of polyaniline based coatings often involves visual obser-

vation and application of both electrochemical and non-electrochemical experimental techniques.

The results of visual observation are usually given as photographs of samples with polyaniline based coatings exposed to the corrosion environment; these results unambiguously indicate protection by polyaniline.

The most popular electrochemical techniques used for estimations of the protection efficiency of polyaniline based coatings involve determination of the open circuit potentials, polarization measurements and electrochemical impedance spectroscopy.

Determination of the open circuit potentials is probably the first step in a corrosion study. The movement of the corrosion potential to a more positive region for samples protected by polyaniline based coatings and its dependences during exposure to corrosion environment is used as a evidence of protection, moreover it is not rarely used to support the mechanism of anodic protection.

Polymerization measurements are used to determine corrosion current density and sometimes the corrosion potential, which are the most reliable parameters for the precise information on protection efficiency of a coating. In Figure 5. determination of the protection efficiency of the benzoate doped polyaniline coating on copper exposed to  $0.5 \text{ mol dm}^{-3}$  NaCl is given [14].

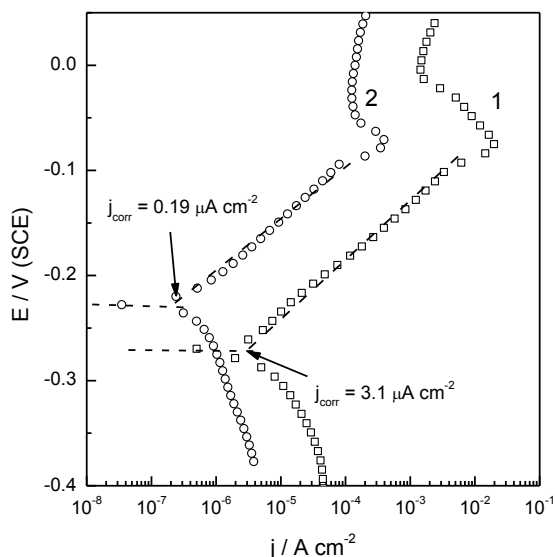

Figure 5 - Potentiodynamic polarization curves ( $v = 1 \text{ mV s}^{-1}$ ) of: 1- copper and 2- copper with polyaniline coating in  $0.5 \text{ mol dm}^{-3}$  NaCl.

Using data on corrosion current density from the Figure 5 it was possible to determine the protection efficiency, which was estimated to nearly 96 %.

Electrochemical impedance spectroscopy (EIS) is intensively used in determination of the protection efficiency of commercial protective coatings [20], but it is also very popular in the field of corrosion protection by electroconducting polymers. The operation principle of EIS involves interpretation of the system response to the application of an input signal in the form of sinusoidal potential of small amplitude. The response of the system is obtained in the form of sinusoidal current. Impedance is practically transient function of this non linear system. Impedance data are referred in either complex plane (Nyquist diagrams) or in frequency plane (Bode diagrams). These results can be interpreted qualitatively or quantitatively using model called electrical equivalent circuit, whose parameters are related to corrosion process and features of the coating [20]. EIS experiments for corrosion studies are practically always performed at open circuit potentials.

The common electrical equivalent circuit used in interpretation of EIS results of commercial organic coating is given in Figure 6., but it is very often used for modeling of the corrosion process of the metals in the presence of polyaniline based coatings.

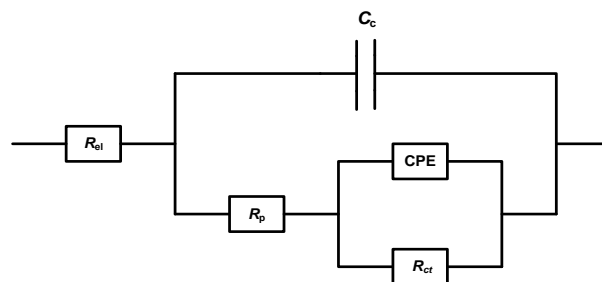

Figure 6 - Common electrical equivalent circuit used to fit EIS data for organic coatings.

The equivalent circuit presented in Figure 6. is particularly useful for evaluation of corrosion protection enhancement of organic coatings when polyaniline modification is used.

The meaning of the circuit parameters is as follows:  $R_{el}$ , electrolyte resistance,  $R_p$ , electrolyte resistance in the pores of the coating,  $R_{ct}$ , charge transfer resistance related to corrosion process (often called polarization resistance),  $C_c$ , coating capacitance, CPE, constant phase element that can be sometimes substituted with double layer capacitance.

Other electrical equivalent circuits can be also found in the literature. Shauer et al [21]. used modified electrical equivalent circuit for steel with polyaniline commercial (Omecon®) based primer and epoxy top coat, given in Figure 7.

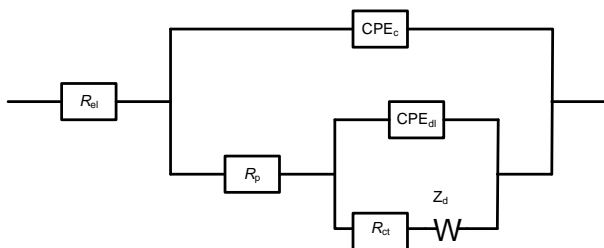

Figure 7 - Electrical equivalent circuit for steel with polyaniline based primer and epoxy top coat, in  $0.5 \text{ mol dm}^{-3} \text{ NaCl}$ .

The coating capacitance is replaced by  $CPE_c$ , constant phase element for the coating and  $Z_d$ , Warburg element was added, without extensive explanation of the physical meaning of these elements. For similar coating system with deliberately made defect, Kinlen et al. [22] used even more complex equivalent circuit, given in Figure 8. New resistance,  $R_{ox}$ , originated from the oxide formed in the defect and polyaniline capacitance,  $C_{PANI}$ , were added to the equivalent circuit.

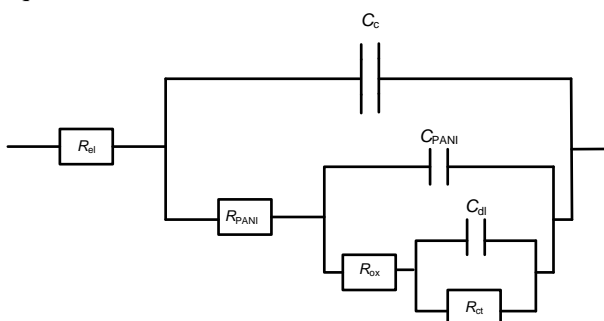

Figure 8 - Electrical equivalent circuit for steel with polyaniline powder dispersed in polymer binder and epoxy top coat, in  $3\% \text{ NaCl}$ .

The evaluation of the equivalent circuit parameters and their time dependences provides valuable information on both the corrosion process and protective features of the coatings itself.

We have used simple electrical equivalent circuit, given in Figure 6., for analysis of EIS data for epoxy coated mild steel and epoxy coated mild steel modified by benzoate doped polyaniline [23,24]. The results of the time dependences of the relevant parameters:  $R_{ct}$ ,  $R_p$ , and  $C_c$  are given together in Figure 9.

As seen in Figure 9., lower values of the  $R_{ct}$ ,  $R_p$  and longer time of the protection (which is seen as linear time dependence of resistances [20]) for polyaniline/epoxy coating system compared to epoxy coating, indicated enhanced protective properties, which were attributed to the presence of polyaniline modification [23,24]. The time dependences of  $C_c$ , followed the values of  $R_p$ , indicated again increase of the protective properties in the presence of polyaniline.

It could be concluded that EIS can be used for modeling of the corrosion process to provide valuable information of the corrosion protection of metals in the presence of polyaniline based coatings. However, impedance results and their modeling differ considerably for similar systems.

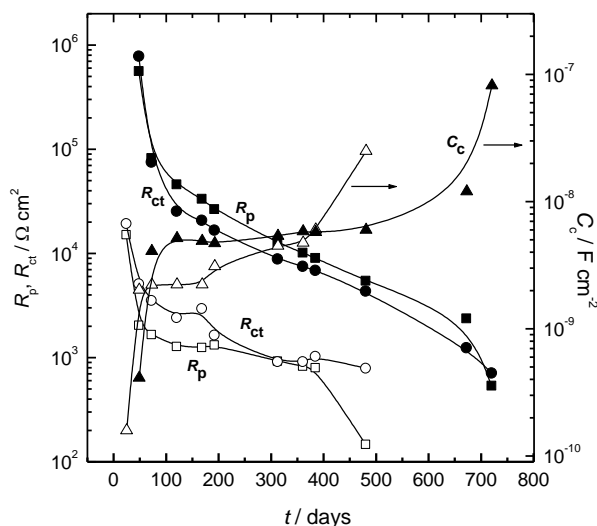

Figure 9 - Time dependences of equivalent circuit parameters for: open symbols- epoxy coated mild steel and full symbols – polyaniline/epoxy coating system in  $1.0 \text{ mol dm}^{-3} \text{ H}_2\text{SO}_4$ .

#### 4.2. Barrier protection

Barrier protection is commonly used to describe corrosion protection by “classical” organic coatings. The protection is achieved by isolating the metal surface from the corrosive environment; the protection is effective as long as the barrier remains intact. Scratches or exposed edges allow contact with corrosion agents, and the corrosion process is initiated and commonly accelerated through cathodic disbondment.

Normally, application of coating would produce sort of barrier effect. Beck has investigated corrosion protection of iron with electrochemically deposited polyaniline, using electrochemical impedance spectroscopy. Lowering of the corrosion rate was observed only for coatings thicker than  $1 \mu\text{m}$ , and this findings were attributed this to barrier effect [25]. Similarly, Weslling noted that reduction in corrosion current was observed for thicker polyaniline coatings [26]. This result, similar to the findings of Beck, might have implied a barrier effect.

#### 4.3. Anodic protection

Many studies have shown that corrosion protection of polyaniline had provided more than a simple barrier protection. The stronger evidence that polyaniline coatings were more than simple barriers, were

given in studies when deliberately made defects were introduced into polyaniline based coatings. Pud et al. have studied corrosion protection of mild steel coated by polyaniline primers with epoxy top coat and epoxy alone, a hole was drilled through coatings to the metal surface [27]. The corrosion rate for mild steel coated by polyaniline/epoxy was significantly lower comparing to epoxy coating alone. The similar findings were observed for scribed samples with polyaniline based primers [22, 28].

Anodic protection mechanism is widely used to describe protection of metals in the presence of polyaniline based coatings. It means that polyaniline metal interface is modified to produce passivating layers with charge transfer reaction occurring between the metal and polyaniline. The anodic protection mechanism is recognized by moving of corrosion potential to passive region for the chosen metal and corrosion environment. This means that, in order to achieve passivation, the corrosion potential must be shifted anodically (ennobled), to the passive region. However, the value of the passivation potential is dependent on the composition and nature of the corrosion media and type of the coated metal or alloy.

Kinlen et al. have proposed simple explanation of the anodic protection mechanism, according to [22]:

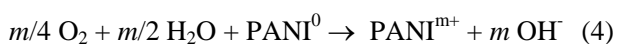
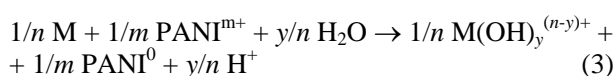

Metal is oxidized, while polyaniline (PANI) is reduced (3), PANI is lately re-oxidized either by atmospheric or oxygen from the solution [22].

As it can be concluded, numerous studies have reported increase in corrosion potential of steel in the presence of polyaniline based coatings so the ennobling of the metal surfaces was evident. Generally, the shift in the corrosion potential has been less pronounced in acidic solution than in neutral sodium chloride solutions. However, several studies reported no change in the corrosion potential in acidic solutions [2, 15].

#### 4.4. Less common mechanisms

Apart from barrier and anodic protection mechanism, there are several less common mechanism found in literature. This involves inhibition of ion diffusion rates, based on variation of the grain – boundaries – pores model for steel [2, 29]. This mechanism is established for the steel corrosion protection by polyaniline in the form of emeraldine base. One other mechanism suggested the displacement of the electroactive interface from metal/solution to

polymer/solution, altering the passive state of the metal. Cathodic and anodic half reactions were separated and the increase in pH at the metal surface is prevented which helped in maintaining stable oxides [21].

## 5. CONCLUSIONS

It is experimentally evidenced that polyaniline based coatings had offered ability of corrosion protection of metals. The establishment of a unique mechanism of corrosion protection is practically impossible, since it is dependent on type of metal, coating, corrosion environment etc. However, some general concepts are known, and most of the literature is interpreted in terms of barrier and anodic protection mechanisms. There is a still growing interest in investigation of polyaniline for the purposes of corrosion protection.

### 6. Acknowledgment

*This work was supported by the Ministry of Education and Science, Republic of Serbia, Project No. 172046*

## 7. REFERENCES

- [1] H. Laterby, J. Chem. Soc. 15 (1862) 161
- [2] D. E. Tallman, G. Springs, A. Dominis, G. G. Wallace, J. Solid State Electrochem. 2002, 6, 85
- [3] S. Biallozor, A. Kupniewska Synth. Met. 2005, 155, 443.
- [4] J. Stejskal, R. G. Gilbert, (IUPAC Technical Report), Pure Appl. Chem. 74 (2002) 857
- [5] J. Stejskal, I. Sapurina, M. Trachová, Prog. Polym. Sci. 35 (2010) 1420
- [6] M. Gvozdenović, B. Jugović, J. Stevanović, T. Trišović, B. Grgur, "Electrochemical polymerization of aniline" in Electropolymerization, Ed. by E. Schab-Balcerzak, Intech, Rijeka, 2012
- [7] A. Elkais, M. Gvozdenović, B. Jugović, J. Stevanović, N. Nikolić, B. Grgur, Prog. Org. Coat. 71 (2011) 32
- [8] N. Gospodinova, L. Terlemezyan, Prog. Polym. Sci. 1998, 23, 1443
- [9] A. MacDiarmid, J. Chiang, A. Richter, A. Epstein, Synth. Mett. 1987, 18, 285
- [10] "Conducting Polymers – Theory, Synthesis, Properties and Characterization", Ed. T. A. Skotheim and J. R. Reynolds, CRC-Press Taylor & Francis Group, New York, 2007.
- [11] A. J. MacDiarmid, A. J. Epstein, Synth. Met. 28 (1989) 629
- [12] J. Kankare, E.-L. Kupila, J. Electroanal. Chem. 322 (1992) 167

- [13] J. L. Camalet, J. C. Lacroix, T. Dung Ngyen, S. Aeiyaich, M. C. Pham, J. Petit Jean, P. C. Lacaze, J. Electroanal. Chem. 485 (2000) 13
- [14] D. H-Vilca, S.de Moraes, A. de Jesus Motheo, J. Solid State Electrochem. 9(2005)416
- [15] Milica M. Popović, Branimir N. Grgur, Synth. Met. 143 (2004) 191
- [16] M. M. Gvozdenović, B. N. Grgur, Prog. Org. Coat. 65 (2009) 401
- [17] M. M. Gvozdenović, B. Z. Jugović, J. Stevanović, B. N. Grgur, T. T. Trišović, Z. Jugović, Synth. Met. 161 (2011) 1313
- [18] N. Ahmad, A. G. MacDiarmid, Synth. Met. 78 (1996) 103
- [19] J. Heinze, B. Frontana-Urbe, S. Ludwings, Chem. Rew. 110 (2010) 4724
- [20] V. Mišković-Stanković, "Organske zaštitne prevlake" – SIZAMS, Beograd 2001.
- [21] T. Schauer, A. Joos, L. Dulog, C. D. Einsebach, Prog. Org. Coat. 33 (1998) 2022
- [22] P. J. Kinlen, D. C. Silverman, C. R. Jeffreys, Synth. Met. 85 (1997) 1327
- [23] M. M. Popović, B. N. Grgur, Vesna Mišković-Stanković, Prog. in Org. Coat. 52 (2005) 359
- [24] B.N. Grgur, M.M. Gvozdenović, V.B. Mišković-Stanković, Z. Kačarević-Popović, Prog. in Org. Coat, 56 (2006) 214
- [25] F. Beck Electrochim. Acta, 33 (1988) 839
- [26] B. Wessling, J. Posdofer, Synth. Met. 102 (1999) 144
- [27] A. Pud, G. S. Shapoval, P. Kamarchik, N. Ogustov, V. F. Gromovaya, I. E. Myronyk, Y. V. Konstur, Synth. Met. 107 (1999) 111
- [28] B. Wessling, Adv. Mater. 6 (1994) 226
- [29] M. Falman, S. Justy, A. J. Epstein, Synth. Met. 85 (1997) 1322

## IZVOD

### PRIMENA POLIANILINA U ZAŠTITI METALA OD KOROZIJE

*Polianilin je najproučavaniji elektroprovodni polimer. Ova popularnost polianilina je posledica jedinstvenih svojstava, delom nasleđenih od polimerne prirode, a delom ostvarenih provodljivošću. Najvažnija svojstva polianilina: postojanje više oksidacionih stanja, elektronska provodljivost, optička aktivnost, postojanost u spoljašnjoj sredini, mogućnost hemijske i elektrohemijske sinteze i niska cena monomera nalaze primenu u mnogim oblastima: elektrohemijskim sistemima za skladištenje i proizvodnju električne energije, elektronicima, za izradu sensorskih i biosensorskih elektroda, za izradu antistatičkih i materijala mikrotalasnih i magnetnih štitova i u zaštiti metala i legura od korozije. Primena polianilina u zaštiti od korozije je prvenstveno motivisana potrebom zamene toksičnih materijala iz sistema prevlaka. Postoji dosta literaturnih podataka iz ove oblasti. Ipak, imajući u vidu raznovrsnost metala i legura, korozivnih sredina, postupaka pripreme materijala, nanošenja prevlaka i vrsta prevlaka, kao i eksperimentalnih procedura i observacija, praktično je nemoguće uspostaviti jedinstven mehanizam antikorozijske zaštite metala u prisustvu polianilina. Najcitiraniji i najpopularniji mehanizmi koji se mogu naći u literaturi obuhvataju barijerni mehanizam i mehanizam anodne zaštite.*

**Ključne reči:** elektroprovodni polimeri, polianilin, zaštita od korozije

Rad primljen: 19. 09. 2012.

Originalni naučni rad